



L12









TM - TERMIC

Load capacity up to 80kg







RIG Made of stamped steel plate and swivel head with double ball raceway, zinc-plated finish. Bolted wheel axle.



WHEEL TM - Termic. Hardness: 90 Shore D. (0°C to + 200°C)
 Manufactured in phenolic resin (bakelite), molded by heat and pressure. Indicated for utilization in high temperature environment applications. They have good mechanical properties, resistant to deformation under static loads and roll easily. They are resistant to most chemicals.

Swivel Caster	Rigid Caster	Wheel				Axle Type (bearing)					
Reference	Reference	Reference	(mm)	(mm)	(pol)		KG	(mm)	w/o brake (mm)	w/ brake G (mm)	w/ brake SL (mm)
GL 312 TM	FL 312 TM	R 312 TM	75	32	5/16"	Plain Bearing	70	103	71	98	80
GL 412 TM	FL 412 TM	R 412 TM	100					126	80		

Fittings/Accessories

					
Axle hole 13mm	Threaded Stem 1/2"NC X 25mm	Threaded Stem 1/2"NC X 64mm	Stem Ø7/16" X 50mm	Aluminum Expander Fitting	Fitting Cap's
Reference	LES	LE	LEX	LEL	See table below

Swivel Sections

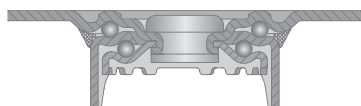

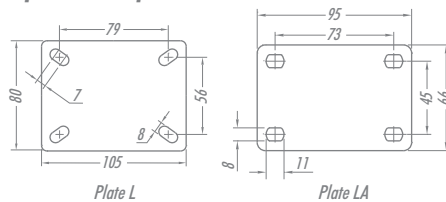

Top Plate Options

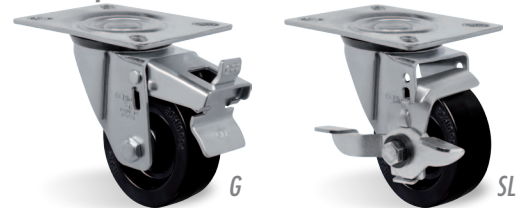

Brake Options



NYLON SOCKET FITTING 		RUBBER EXPANDER FITTING 		ALUMINUM EXPANDER FITTING 		CAP'S N°	THREAD
SIZE (mm)	REFERENCE	SIZE (mm)	REFERENCE	SIZE (mm)	REFERENCE		
Ø38	S1	18 - 21	EX 1	21 - 27	EA 2	T1	1/2" BSP
Ø30	S2	21 - 24	EX 2	27 - 33	EA 4	T2	3/4" BSP
Ø25	S3	25 - 28	EX 3			T3	1" BSP
40X40	S4	27 - 30	EX 4				
		37 - 40	EX 5				